

International Journal of Research in Pharmaceutical and Nano Sciences

Journal homepage: www.ijrpns.com



PROLIPOSOMES AS A NOVEL DRUG DELIVERY SYSTEM FOR THE IMPROVEMENT OF VESICULAR STABILITY

M. V. Shruthi^{*1}, S. Parthiban¹, G. P. Senthilkumar², T. Tamizmani³

^{1*}Department of Pharmaceutics, Bharathi College of Pharmacy, Bharathinagara, Mandya, Karnataka, India.

²Department of Pharmaceutical Chemistry, Bharathi College of Pharmacy, Bharathinagara, Mandya, Karnataka, India.

³Department of Pharmacognosy, Bharathi College of Pharmacy, Bharathinagara, Mandya, Karnataka, India.

ABSTRACT

Liposomes are the most promising and broadly applicable of all the novel drug delivery systems. The shelf life of liposomal suspensions can be limited; it would be useful to have a method of producing liposomes quickly, at the point of use and without excessive manipulation. These needs are met by the “proliposome” method. Proliposome are simply soluble particles covered with liposome precursors which, when dissolved in water, will produce liposomes. Payne *et al* (1986a, 1986b) originally developed this method. The focus of this review is to bring out different aspects related to liposomes, Proliposomes preparation, characterization, merits and highlights its potential to be exploited for different routes of administration.

KEYWORDS

Liposome, Proliposomes, Carriers, Phospholipids and Cholesterol and Unilamellar.

Author for Correspondence:

Shruthi M V,
Department of Pharmaceutics,
Bharathi College of Pharmacy,
Bharathinagara, Mandya, Karnataka, India.

Email: shruthimvpharma@gmail.com

INTRODUCTION

The ideal drug delivery system delivers drug at a rate dictated by the need of the body over the period of treatment and it channels the active entity solely to the site of action. At present no available drug delivery systems can achieve all these goals. The targeted drug delivery system achieves the site specific delivery but is unable to control the release kinetics of drug in predictable manner. Since then numerous attempts have been made to device clinically effective drug delivery system(s). Number

of carriers were utilized to carry drug at target organ/tissue which include immunoglobulins, serum proteins, synthetic polymers, lipid vesicles (liposomes), microspheres, erythrocytes, reverse micelles, niosomes, pharmacosomes etc. amongst the various carries, few drug carriers reached drug delivery to the site of action. These carriers (liposome) are biologically inert in nature, devoid of any antigenic, pyrogenic or allergic reactions and their components can be utilized as the component of biological membrane. Drug incorporated in liposomes are not inactivated under physiological conditions and do not cause unfavorable side effects as well¹.

Structurally, liposomes are concentric bilayer vesicles in which an aqueous volume is entirely enclosed by a membranous lipid bilayer mainly composed of natural or synthetic phospholipids².

There are many approaches to production of liposomes and each method has inherent advantages and limitations. Since the shelf life of liposomal suspensions can be limited, it would be useful to have a method of producing liposomes quickly, at the point of use and without excessive manipulation. These needs are met by the "proliposome" method. Proliposome (PLs) are simply soluble particles covered with liposome precursors which, when dissolved in water, will produce liposomes. Payne et.al (1986a, 1986b) originally developed this method³. Being available in dry powder form, they are easy to distribute, transfer, measure and store making it a versatile system. Liposomes can either be formed *in vivo* under the influence of physiological fluids or can be formed *in vitro* prior to administration using a suitable hydrating fluid. The liposomes formed on reconstitution are similar to conventional liposomes and more uniform in size⁴.

Advantages of proliposomes⁵

- Targeting of anti-cancer drugs to tumor sites.
- Targeting of drugs to non-RE tissues, which has not been possible with conventional liposomes.
- Proliposomes can use for controlling release within the vasculature by manipulating the phospholipid composition of bi-layers.

- For the diseases of vascular origin, proliposomes provide the best therapeutic effect over conventional drug.

Comparisons between liposomes and proliposomes⁶

Liposomes are unilamellar or multilamellar spheroid structures composed of lipid molecules, often phospholipids. They show controlled release and increased solubility but have a tendency to aggregate or fuse, susceptible to hydrolysis or oxidation.

Proliposomes an alternative forms to conventional liposomal formulation composed of water soluble porous powder as a carrier, phospholipids and drugs dissolved in organic solvent. Lipid and drug are coated onto a soluble carrier to form free-flowing granular material show controlled release, better stability, ease of handling and increased solubility.

Components used for the preparation of proliposomes

Water soluble carriers⁷

The carrier's chosen should have high surface area and porosity so that the amount of carrier required can be easily adjusted to support the lipids. It also enables high surfactant to carrier mass ratio in the preparation of proliposomes. Further, being water soluble they allow rapid formation of liposomal dispersion on hydration and by controlling the size of porous powder, relatively narrow range of reconstituted liposomes can be obtained. Some of the carriers utilized include- maltodextrin, sorbitol, microcrystalline cellulose, magnesium aluminium silicates, Mannitol etc.

Phospholipids⁸⁻⁹

The bulk components of liposomal lipid membrane are phosphotindyl glycerides (phospholipids), amphipathic molecules that consist of a hydrophilic phosphate head group and hydrophilic fatty acid chains bridged together by a glycerol back bone. In early studies, egg phosphatidyl choline (egg PC, egg lecithin) was used and these phospholipids. Although exhibiting a single head group composition, contain various lipid species due to the presence mixed and varying acyl chain lengths. More recently highly purified lipids have been chemically synthesized consisting of saturated fatty

acid species with same numbers of carbons. The fatty acid chain can vary between 8-24 carbons (C8-C24); among them three mostly used in liposomal drug delivery are myristic (C14), palmitic (C16) and steric (C18). Aside from the fatty acid carbon length, the phosphate group can varied and include phosphatidylcholine (PC). Phosphotindly ethanolamine (PE), which are zwitterion (charge balanced with positive charge on head group and negative charge on phosphate group), the negatively charged phosphatidly, serine, glycerol inositol head group. Many of physicochemical properties of liposomes such as stability, permeability, phase behavior and membrane order depend on the fatty acid chain length and saturation.

Steroids⁸⁻⁹

Cholesterol is a generally used steroid in the formulation of liposomes to membrane and reduces the permeability of water- soluble molecules through the membrane and improves the stability of bilayer membrane in the presence of biological fluids such as blood/plasma. Liposomes without cholesterol ten to react with the blood proteins such as albumin, m-transferrin and macroglobulin, which tend to destabilize the liposomes. Cholesterol appears to reduce these interactions with blood proteins.

Solvents¹⁰

They are used to for providing the softness for vesicle membrane. Examples of solvents are methanol and chloroform.

Method of preparation of proliposomes

Proliposome could be prepared by many methods such as:

- Film- deposition on carrier method.
- Fluidised-bed method.
- Spray drying method.
- Super critical antisolvent method.

Film- deposition on carrier method¹⁻¹¹

For preparing proliposome by this method special equipment as Buchi rotary evaporator 'R' with water cooled condenser coil and a stainless steel covered thermocouple connected to a digital thermometer, is required. The end of the glass solvent inlet tube is modified to a fine point, so that

the solvent is introduced into the flask as a fine spray.

Procedure

The solution of lipid and drug in volatile organic solvent is prepared and carrier powder is introduced into 100ml flask. The flask is then fitted into the evaporator and rotated slowly so that the powder tumbles gently off the walls to ensure good mixing and the solvent is evaporated. The flask is lowered into a water bath at 50-55⁰C when a good vacuum as developed (around 100 KPa). An aliquot of 5ml of lipid solution is introduced into the flask via the solvent inlet tube. The solvent is absorbed completely by the powder and the temperature of the bed is monitored. As evaporation proceeds, the temperature will decrease. A second aliquot is introduced slowly when the temperature begin again. The temperature allowed rising to 30⁰C, the vacuum is released and drying process is completed by connecting the flask containing the powder to lyophilize and leaving it evacuated overnight at room temperature.

For use, introduce 10ml of distilled water into one vial and mix on a whirl mixer for 30sec. or in shaking water bath above the lipid phase transition temperature, to give a 5%w/v solution of sorbitol(isotonic with normal saline) and a lipid concentration of 10mg/ml.

Care must be taken not to allow temperature rise too high if working with low melting temperature (e.g. egg PC) otherwise agglomeration of powder particles will result.

Fluidised bed method¹²⁻¹³

Principle

It works on the principle of particle coating technology.

Usage of carrier material

The carrier material used here can vary from crystalline powder to non pareil beads. When using beads as carrier material, initial seal coating is applied to the beads to provide a smooth surface for further coating of phospholipids. This ensures formation of thin uniform coating of phospholipid around the core and formation of smaller sized liposomes upon hydration.

Procedure

Solution of drug and phospholipid in organic solvent is sprayed onto the carrier material through a nozzle. At the same time, the organic solvent is removed by applying vacuum to the fluid bed. To remove the trace amount of residual solvent the finished lipid-coated powder/beads can be dried under vacuum overnight.

Advantages

- It utilizes Film coating technology which is well established and process able.
- Various cores and coating materials are available or easy to prepare.
- It is a cost-effective method to prepare liposomes for drug delivery.

Spray drying method¹⁴⁻¹⁶

This method is mainly used when particles of uniform size and shape are required and can be easily scaled up it is cost effective and suitable for large scale production of proliposomes. The unique feature of spray drying process lies in its ability to involve both particle formation and drying in a continuous single step, allowing better control of particle. Spray drying is not only limited to aqueous solutions, but can also be used for non-aqueous systems to prepare particles.

The spray drying process involves four stages:

1. Atomization of the product into a spray nozzle.
2. Spray-air contact.
3. Drying of the spray droplets, and
4. Collection of the solid product.

Procedure

Initially liquid dispersions containing pure lipid or lipids and carrier in organic solvent are prepared and pumped into the drying chamber. The dispersions are atomized into the drying chamber using a spray nozzle and are dried in a concurrent air flow which is then collected in a reservoir.

Major concerns to spray drying are high working temperatures, shearing stresses and absorption phenomenon that may lead to thermal and mechanical degradation of the active molecules. This can be improved by optimising the operating parameters such as drying air temperature and liquid spraying rate. Stabilising adjuvants such as

disaccharides, cyclic oligosaccharides and polyols can also be used to protect the integrity of the active molecules and enhance the efficiency of hydration by increasing the surface area of lipids.

Super critical anti-solvent method¹⁷⁻¹⁸

Supercritical anti-solvent method utilizes Supercritical Carbon dioxide (SCCO₂) in the preparation of PLs. SCCO₂ is a fluid state of carbon dioxide where it is held at or above its critical temperature and pressure. Antisolvent technology is widely used in food industry and was developed to prepare PLs because of its lower residual solvents, simpler steps and mild operation temperatures.

As shown in Figure No.1, the apparatus used in the preparation of PLs include three parts:

- A sample delivery unit,
- A precipitation unit and
- A separation unit.

The sample delivery unit consists of two pumps: one for CO₂ and the other for solution. CO₂ is supplied from the CO₂ cylinder (1) which is cooled down by a refrigerator (2) and introduced via a high pressure pump (3) to the buffer tank (4), in which it is preheated. The drug solution is introduced via HPLC pump (11). The solvent used for dissolving the drug should be completely miscible with CO₂. Opening the valves A and B allows the entry of solution and CO₂ into the vessel through the nozzle (B). As seen in Fig 3.B, solution is sprayed through the inner tubule whereas CO₂ is sprayed through the outer tubule of the nozzle. The precipitation unit consists of a vessel (9) heated by an air bath. The separation unit consists of a separator (13) and a wet gas meter (14). The organic solvent is separated from SCCO₂ in the separator because of lower pressure whereas volumetric flow rate of CO₂ is measured by the wet gas meter. After the temperature and pressure of the separating vessel reaches the present value, valve A is opened to allow entry of CO₂ followed by opening of valve B allowing the entry of drug solution. SCCO₂ and solution are mixed and diffused into one another rapidly as they are sprayed through the coaxial nozzle. This causes the solutes dissolved in organic solvent to reach super saturation in a very short period of time because the

solubility of solutes in the organic solvent decreases greatly. As a result, the PLs are precipitated in the vessel. Once the solution is completely utilized, valves A and B are closed while valve C is opened in order to depressurize the vessel at the operating temperature. The samples are collected on the filter (8) at the bottom of the vessel. The pressure, temperature and flow rate of the drug solution need to be optimized to obtain high drug loading in proliposomes.

CHARACTERIZATION OF PROLIPOSOMES

The proliposomes are evaluated by following are the parameters:

Vesicle Size determination

Vesicle Size determination is one of the most important parameter for vesicular system. This can be carried by hydrating the proliposomes powder and determining vesicle size using suitable Particle size analyzer or determined by using an optical microscope with a calibrated eyepiece micrometer⁷.

Scanning Electron Microscopy (SEM)

Surface morphology of proliposomes and plain water soluble carrier were examined by a scanning electron microscope. After gold coating of proliposome and plain water soluble carrier, their surface morphology was viewed. This involves comparing the image of the pure carrier material with that of the proliposomes. The SEM image of the carrier material confirms the deposition of phospholipid on the carrier and thus confirming the formation of proliposomes¹⁹.

Transmission Electron Microscopy (TEM)

TEM is mainly used to study the morphology of the liposomes from proliposome upon hydration and observing the shape and lamellarity of the liposome vesicles formed under the microscope⁷⁻¹⁹.

Hydration Study

Hydration study is to evaluate the ability of proliposomes to form liposomes on hydration. It is carried by placing a small amount of proliposomes powder on glass slide slowly adding water drop wise while observing it under the microscope to view the formation of vesicles^{7, 19}.

Zeta potential

The zeta Potential is defined as the difference in potential between the surface of the tightly bound layer (shear plane) and the electro-neutral region of the solution. This can be used to study the surface charge of the particles²⁰.

Flow Property

It ensures the despite the deposition of phospholipids on carriers, the flow ability of particles is not affected. This can be done by measuring the parameters such as Angle of Repose, Carr's Index or Compressibility Index and Hausner's Ratio⁷⁻¹⁹.

Entrapment Efficiency

Entrapment efficiency is carried by hydrating the proliposomes to form liposome dispersion followed by separation of untrapped drug and determining the amount of drug entrapped. The untrapped drug can be separated by cooling ultracentrifugation⁷.

Percent drug entrapment is calculated by using the following formula:

Entrapped Drug X 100/Total Amount of Drug added

Application

Proliposomes can be exploited for the following routes of administration:

Oral delivery

Oral drug delivery continues to be the preferred route of administration, but liposomes have limited success in delivering drugs through oral route. This is due to the absence of a stable dosage form oral delivery and erratic and unpredictable absorption profiles shown by liposomes. Being available as free flowing powder, PL represents the first example of delivering liposomes into solid dosage form such as tablets or capsules. Further, liposomes are formed on contact with biological fluids at the site of absorption ensuring the retention of liposome integrity.

Zaleplon is a hypnotic drug indicated in insomnia and is a potential anticonvulsant. Due to its limited aqueous solubility and extensive first pass metabolism it shows poor bioavailability of 30%. PLs for oral delivery of Zaleplon and found 2-5 fold improvement in oral bioavailability in rats compared

to pure drug⁴.

Arthritis

Drug that are being in arthritis especially steroids, are destroyed by their peripheral effect. On local administration into the joints, drug diffuses easily from the site of injection and its action on the inflamed area is only transient. Segal et.al suggested that liposomes could be used in the treatment of local diseases. It is observed that steroids (e.g. cortisol palmitate) can be entrapped into large multilamellar liposomes composed of dipalmitoyl phosphatidyl choline and phosphatidic acid. These preparations, when ingested into rabbits with experimental arthritis, can decrease the temperature as well as the size of the joints to a greater extent than with a similar amount of free steroids¹.

Diabetes

The feasibility of using liposomes as a potential delivery system of the oral delivery of insulin has been extensively studied. Alteration in blood glucose level in diabetic animals was obtained by the oral administration of liposome encapsulated insulin. Dobre *et.al* demonstrated a lowering of blood glucose level in normal rats following the oral administration of insulin entrapped in PC: CH liposomes¹.

Parenteral delivery

PLs are well suited for parenteral application of liposomes. The main advantage associated with PLs is that it allows sterilization without affecting the intrinsic characteristics¹¹. Besides, they can be stored as sterilized in dry state and can be hydrated prior to administration to form multilamellar liposomal suspension²¹.

Pulmonary Delivery

Major advantage of liposomes as pulmonary drug delivery system is that they are prepared from phospholipids which are endogenous to lungs as component of lung surfactant. Drug encapsulation in liposomes provides modulated absorption, resulting in localized drug action in the respiratory tract and prolonged drug presence in circulation and reduced systemic adverse effects^{22, 23}.

Drug delivery to the pulmonary route is achieved by three types of devices namely

Pressurised metered dose Inhalers (pMDI)

As the name suggests it consists of solution or suspension of drugs in liquefied propellants. Use of Hydrofluoroalkanes as non-ozone depleting propellants over CFCs has the limitation for liposome delivery as they are poor solvents for phospholipids. Proliposomes help overcome this limitation as they can be suspended in these propellants and serve as carrier for pulmonary delivery of liposomes through pMDI²².

Dry Powder Inhalers (DPIs)

These disperse the drug into the patient's airstream as a fine powder during inhalation. Delivering liposomes through DPI have many advantages such as controlled delivery, increased potency, and reduced toxicity, uniform deposition of drugs locally, patient compliance, stability and high dose carrying capacity. Being available as dry powder form, PLs are the best alternative for delivering liposomes through DPIs. Chougule et.al developed spray dried liposome encapsulated Dapsone DPI for prolonged drug retention in lungs to prevent *Pneumocystis carinii* pneumonia. Prolonged drug release of up to 16 h was observed *in vitro*^{22, 24}.

Nebulizers

Nebulization offers the simplest means, for delivering liposomes to the human respiratory tract but it is concerned with liposome leakage and drug stability. Use of dry powder formulations has been suggested to overcome these issues. Lyophilisation and jet milling may be used to obtain dry powder but tend to have deleterious effect on liposomes due to the stresses involved in these processes. Thus, PLs serve as a stable alternative for delivering liposomes through nebulization. Besides, the ready formation of an isotonic liposome formulation *in situ* from PLs seems to offer advantages over other formulation approaches^{22, 23}.

Mucosal delivery

PLs form vesicular structures (liposomes) *in vivo*, triggered by the aqueous environment found on the mucosal surfaces. Phospholipids present in them have natural affinity for biological membranes. Besides they are generally nontoxic and non-irritant. The presence of drug as molecular dispersion in the

bilayers offers improved drug activity. Further, the difficulties associated with liposomal preparations such as stability and loading are circumvented because the PLs convert to vesicular structures *in vivo*, i.e., on the mucosa²⁵.

Vaginal delivery systems are frequently required to treat local fungal infections. The poor aqueous solubility of antifungal and steroid compounds in conventional formulations limits their presence as molecular dispersion and consequently affects the drug concentration at active sites. The associations of these lipophilic agents with the phospholipid molecules of proliposome make them excellent carriers to molecularly disperse the drug²⁵.

Nasal mucoadhesive delivery has been used to improve local and systemic delivery of therapeutic compounds²⁶. Limitations associated with this route are mucociliary clearance which limits the residence time of drug in the nasal cavity and lack of sustained release of drugs with short half-life^{27,28}. Proliposomal delivery helps to overcome these limitations. Liposomes formed on hydration decrease the mucociliary clearance of drug due to their surface viscosity and provide intimate and prolonged contact between the drug and mucus membrane^{29,30}.

Transdermal delivery

Phospholipids, being the major component of liposomal system, can easily get integrated with the skin lipids and maintain the desired hydration conditions to improve drug permeation. When PLs are applied to mucosal membrane, they are expected to form liposomes on contact with mucosal fluids whereby the resulting liposomes act as sustained release dosage form for loaded drugs. Liposomes formed on hydration have the ability to modulate diffusion across the skin. They do so by fusing with the skin surface and establishing concentration gradient of the intercalated drug across the skin. Thus they enhance skin permeation. Also, the vesicle intercalation into the intracellular lipid layers of the skin results in fluidization and disorganization of the regular skin structure, obviating the barrier function of the stratum corneum^{21, 31}.

Ophthalmic delivery of drugs

The potential of liposomes in topical ocular drug delivery was first focused by Smolin et al. Schaeffer and Krohn and Schaeffer *et al.* liposomes offer advantages over most ophthalmic preparation in being completely biodegradable and relatively non-toxic. Smolin et al. reported the treatment of acute and chronic herpetic keratitis in albino rates, idoxuridine entrapped in liposomes was more effective than a comparable therapeutic regimen of untrapped drug. Schaeffer *et al.* reported that transcorneal flux of penicillin G, indoxol and Carbachol were approximately double when these drugs were presented to the corneal surface in liposomal form. In direct contrast to these findings, Starford et al., observed a reduction in the fraction of epinephrine and inulin absorbed into aqueous humor in liposomes¹.

Liposomes as carrier for vaccines

Liposomes as immunological adjuvants

Studies on cardiolipin (naturally occurring lipids) revealed the imported of bilayer structure in production of antisera and concluded that liposomes are in fact responsible for the antigenicity of the lipids. In addition, liposomes also have an adjuvant effect upon protein antigen. Liposomes can serve as an effective for inducing HI to wide range liposomal antigens.

The size and structure of liposomes may be modulated as required which effect the immunogenic of liposomised antigens. Studies on HLVs and ULVs of comparable size promoting antibody response revealed that ULVs are more effective than HLVs to entrap BSA.

Liposomes made from the lipids with temperature above the ambient temperature (37⁰C) are known to behave differently from liposomes made from lipids whose Tcs are below the ambient temperature with interacting with the cells. Liposomes composed of Dipalmitoyl phosphatidyl choline and Distearoyl phosphatidyl choline (Tc: 41.0⁰C and 55.4.9⁰C, respectively) have been reported to be more effective immunogens than those prepared from egg PC because of the greater bilayer stability at

physiological temperature and stronger immune-potentiating property¹.

Liposomes as carrier of antigens

In addition their adjuvant effect, liposomes have been recognized as efficient carrier to deliver biologically active material to specific cells. However, on administration of liposomes the major fraction is taken up by the liver and spleen unless steps are taken to retard their uptake.

The following criteria help in successful homing of liposomised agent to target cells.

- Rate of uptake of liposome by RES must be minimized by using small, neutral, unilamellar liposomes having higher Tc and cholesterol.
- By coupling the surface of liposomes which would render liposomes less recognizable by RES.
- Coupling appropriate molecules (ligands) on the liposome surface which can bind to their receptors on the surface of target cell¹.

Literature review on proliposomes drug delivery system

Diwan et al., studied on proliposomal gel bearing a steroidal anti-inflammatory agent Prednisolone intended for topical application. They prepared proliposomes by thin film hydration technique by using varying the lipid phase composition (lecithin/cholesterol) and reported that Prednisolone proliposomal gel showed sustain release with enhanced anti-inflammatory activity implicating its potential in effective topical pharmacotherapy for the treatment of rheumatoid arthritis³².

Malleesh Kurakula et al., studied on proliposomal gel bearing a non-steroidal anti-inflammatory agent, Piroxicam intended for topical application. Proliposome formulations were prepared by thin film hydration technique using varying the lipid phase composition (lecithin/ cholesterol). They reported that the Piroxicam proliposomal gel showed sustain release with enhanced anti-inflammatory activity implicating its potential in effective topical pharmacotherapy for the treatment of rheumatoid arthritis³³.

Arpana Patil-Gadhe et al., prepared Rifapentine-loaded proliposomes for the treatment of tuberculosis by spray drying method and independent variables were optimized using factorial design approach. The study results demonstrated the application of quality by design principles and design of experiment approach to develop drug encapsulated proliposomes for inhalation by spray drying in single step³⁴.

Chuandi Sun et al., investigated the possibility of liquid proliposomes being carriers for oral delivery. They prepared Nimodipine liquid proliposomes-based soft capsules and reported that proliposomes shows potential way to improve oral delivery of Nimodipine³⁵.

Rajesh Kumar et al., formulated proliposomes in the form of enteric-coated beads using Glyburide as a model drug. The beads were enteric coated with Eudragit L-100 by a fluidized bed coating process using triethyl citrate as plasticizer. The dissolution study of enteric-coated beads exhibited enhanced dissolution compared with pure drug and a marketed product³⁶.

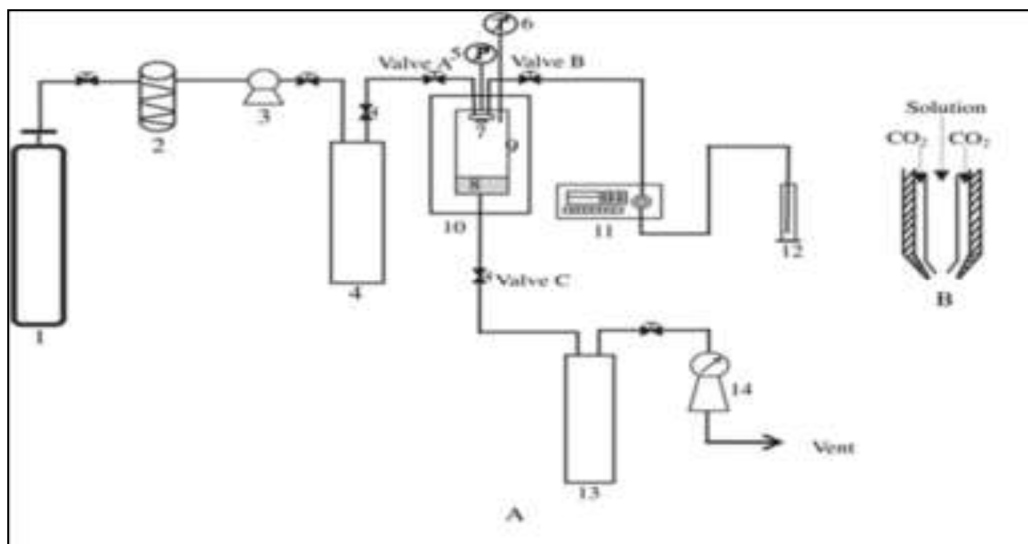

Figure No.1: Apparatus for preparing PLs by Supercritical Anti Solvent Method

CONCLUSION

Proliposomes exhibited superior shelf life as compared to liposomes and it offers non-invasive delivery of drug into or across the skin. Since better stability of liposomes *in vitro* is observed with proliposomes, the proliposomes would be proper choice of preparation method. Introduction of proliposomes has initiated a new area in vesicular research for topical drug delivery. Different reports show a promising future of proliposomes in making transdermal delivery of various agents.

ACKNOWLEDGEMENT

All authors would like to thank Bharathi College of Pharmacy, Bharathinagara, Mandya, Karnataka, India for supporting for the fulfilment of this work.

CONFLICT OF INTEREST

We declare that we have no conflict of interest.

REFERENCES

1. Sanjay K Jain and Jain N K. Controlled and novel drug delivery, *CBS publishers and distributors, Delhi*, 2003, 304-341.
2. Vyas S P and Khar. Targeted and controlled drug delivery (Novel carriers systems), *CBS publishers and distributors, Delhi*, 2006, 173-181.

3. Ljeoma F Uchegbu. Synthetic surfactant vesicles: niosomes and other non-phospholipid vesicular systems, *Publisher: CRC Press*, 2000, 93-96.
4. Jessy Shaji and Vinay Bhatia. Proliposomes: A brief overview of novel delivery system, *Int Pharm Bio Sci*, 4(1), 2013, 150-160.
5. Gangadharappa H V, Gangadhar Veerapu, Nagashubha B. Approaches for improvement of vesicular system-Pro-vesicular drug delivery, *Am J Pharm Tech Res*, 4(1), 2014, 17-57.
6. Saurabh Bansal, Chandan Prasad Kashyap, Geeta Aggarwal and Harikumar S L. A comparative review on vesicular drug delivery system and stability issues, *IJRPC*, 2(3), 2012, 04-713.
7. Janga K Y, Jukanti R, Velpula A. Bioavailability enhancement of Zaleplonvia proliposomes: Role of surface charge, *Euro J Pharm and Biopharm*, 80(2), 2012, 347-357.
8. Lasic D D, Papahadjopoulos D. Liposomes and biopolymer in drug and gene deliver, *Current Opinion in Solid State and Materials Science*, 1(3), 1996, 392-400.
9. Gabizon A, Papahadjopoulos D. Liposome formulation with prolonged circulation time in blood and enhanced uptake by tumors, *Proc Notl Acad Sci (USA)*, 85(18), 1988, 6949-53.

10. Gupta V, Barupal A K, Ramteke S. Formulation development and *in vitro* characterization of proliposomes for topical delivery of Aceclofenac, *Indian J Pharm Sci*, 70(6), 2008, 768-75.
11. Song K H, Chung S J, Shim C K. Preparation and evaluation of proliposomes containing salmon calcitonin, *J Control Rel*, 84(1-2), 2002, 27-37.
12. Chen C M. Use of fluidised bed in proliposome manufacturing, *J pharm sci*, 76(5), 1987, 330.
13. Liu R, Cannon J B, Paspal S Y L. Liposomes in Solubilization. In: Rong Liu (ed.), *Water-Insoluble Drug Formulation*, Taylor and Francis, Boca Raton, 2008, 376-409.
14. Lo Y L, Tsai J C, Kuo J H. Liposomes and disaccharides as carriers in spray-dried powder formulations of superoxide dismutase, *J Control Rel*, 94(2-3), 2004, 259-272.
15. Colonna C, Conti B, Genta I, Alpar O H. Non-viral dried powders for respiratory gene delivery prepared by cationic and chitosan loaded liposomes, *Int J Pharm*, 364(1), 2008, 108-118.
16. Alves G P, Santana M H A. Phospholipid dry powders produced by spray drying processing: structural, thermodynamic and physical properties, *Powder Technology*, 145(1), 2004, 139-148.
17. Xia F, Hu D, Jin H, Zhao Y, Liang J. Preparation of lutein proliposomes by supercritical anti-solvent technique, *Food Hydrocolloids*, 26(2), 2012, 456-463.
18. Fei X, Heyang J, Yaping Z, Xinqiu G. Supercritical Antisolvent-based Technology for Preparation of Vitamin D3 Proliposome and Its Characteristics, *Chinese Journal of Chemical Engineering*, 19(6), 2011, 1039-1046.
19. Xiao Y Y, Song Y M, Chen Z P, Ping Q N. Preparation of Silymarin proliposome: A new way to increase oral bioavailability of Silymarin in beagle dogs, *Int J Pharm*, 319(1-2), 2006, 162-168.
20. Martin A. *Physical Pharmacy*, Lippincott Williams and amp; Wilkins, Philadelphia, PA, 4th edition, 1993, 386-388.
21. Hwang B Y, Jung B H, Chung S J, Lee M H, Shim C K. *In vitro* skin permeation of nicotine from proliposomes, *J Control Rel*, 49(2-3), 1997, 177-184.
22. Taylor K M G, Elhissi A M A. Preparation of Liposomes for Pulmonary Delivery Using Medical Nebulizers. In: Gregory Gregoriadis (ed.), *Liposome Technology Liposome Preparation and Related Techniques*, Informa Healthcare, London, 3rd edition, 1, 2007, 67-84.
23. Sweeney L G, Wang Z, Loebenberg R, Wong J P, Lange C F, Finlay W H. Spray freeze-dried liposomal ciprofloxacin powder for inhaled aerosol drug delivery, *Int J Pharm*, 305(1-2), 2005, 180-185.
24. Chougule M, Padhi B, Misra A. Development of Spray Dried Liposomal Dry Powder Inhaler of Dapsone, *AAPS Pharm Sci Tech*, 9(1), 2008, 47-53.
25. Leigh M. Supra Vail Vaginal Gel. In: Michael J. Rathbone, Jonathan Hadgraft, Michael S. Roberts (eds.), *Modified-Release Drug Delivery Technology*, Marcel Dekker, NewYork, 2003, 791-800.
26. Ugwoke M I, Agu R U, Verbeke N, Kinget R. Nasal mucoadhesive drug delivery: Background, applications, trends and future perspectives, *Adv Drug Del Rev*, 57(11), 2005, 1640-1665.
27. Martin E, Schipper N G M, Verhoef J C, Merkus F W H M. Nasal mucociliary clearance as a factor in nasal drug delivery, *Adv Drug Del Rev*, 29(1-2), 1998, 13-38.
28. Illum L. Nasal drug delivery: new developments and strategies, *Drug Discov Today*, 7(23), 2007, 1184-1189.
29. Arora P, Sharma S, Garg S. Permeability issues in nasal drug delivery, *Drug Discov Today*, 7(18), 2002, 967-975.
30. Ahn B N, Kim S K, Shim C S. Proliposomes as an intranasal dosage form for the sustained delivery of Propranolol, *J Control Rel*, 34(3), 1995, 203-210.
31. Jukanti R, Sheela S, Bandari S, Veerareddy P R. Enhanced bioavailability of Exemestane via

- proliposomes based transdermal delivery, *J Pharm Sci*, 100(8), 2011, 3208-3222.
32. Mallesh Kurakula, Srinivas C, Nagasree Kasturi, Prakash V Diwan. Formulation and Evaluation of Prednisolone Proliposomal Gel for Effective Topical Pharmacotherapy, *IJPSDR*, 4(1), 2012, 35-43.
33. Mallesh Kurakul, Nikitha Pasula, Ranjith Kumar, Pratap Chowdary. Piroxicam proliposomal gel -A novel approach for topical delivery, *J Pharm Res*, 5(3), 2012, 1755-1763.
34. Arpana Patil-Gadhe and Varsha Pokharkar. Single step spray drying method to develop proliposomes for inhalation: A systematic study based on quality by design approach, *Pulmonary Pharmacology and Therapeutics*, 27(2), 2014, 197-207.
35. Chuandi Sun, Ji Wang, Jianping Liu, Wenli zhang. Liquid proliposomes of Nimodipine drug delivery system: Preparation, characterization, and pharmacokinetic, *AAPS Pharm Sci Tech*, 14(1), 2013, 332-338.
36. Rajesh Kumar, Ram B, Gupta, Guru V Betageri. Formulation, characterization and *invitro* release of glyburide from proliposomal beads, *Drug deliv*, 8(1), 2001, 25-27.

Please cite this article in press as: Shruthi M V. *et al.* Proliposomes as a novel drug delivery system for the improvement of vesicular stability, *International Journal of Research in Pharmaceutical and Nano Sciences*, 3(4), 2014, 326-336.